

High Demand Questions

QUESTIONSHEET 1

Some students made a simple cell. Two pieces of metal foil were dipped into a beaker containing salt solution as shown in the diagram below.

The voltage was measured.

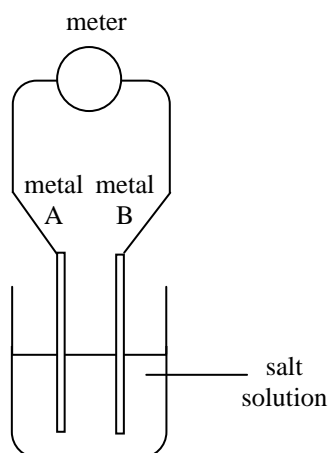

- (a) Name the piece of apparatus that was used to measure the voltage.

..... [1]

The results are given in the table below:

EXPERIMENT	METAL A	METAL B	VOLTAGE OBTAINED/volts
1	magnesium	copper	1.6
2	zinc	copper	0.6
3	iron	copper	0.3
4	copper	copper	0.0

- (b) What is the pattern between the reactivity of the metal and the voltage obtained?

.....
 [3]

- (c) Predict the voltage obtained if aluminium was used as metal A and copper was used as metal B.

..... [1]

- (d) Predict the voltage obtained if metals A and B were swapped over in experiment 1.

..... [1]

- (e) When silver was used as metal A voltage of 0.05 volts was obtained.
 Explain this result.

.....
 [1]

- (f) Give one disadvantage of making electrical cells using this method.

..... [1]

High Demand Questions

QUESTIONSHEET 2

Small pieces of four different metals were placed in identical amounts of hydrochloric acid. The results are shown below.

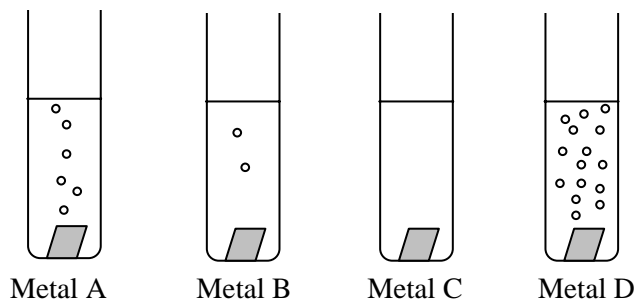

- (a) Place the metals on order of reactivity, starting with the most reactive.

_____ [2]

- (b) The four metals used in the experiment were calcium, magnesium, iron and platinum. Use your knowledge of these four metals to identify the metals A, B, C & D. [3]

Metal A
 Metal B
 Metal C
 Metal D

- (c) When magnesium meets with hydrochloric acid, it forms magnesium chloride and hydrogen.

- (i) Balance the following equation

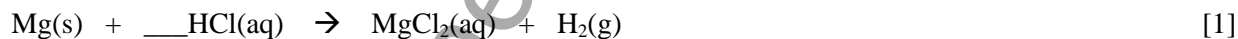

- (ii) When magnesium reacts with sulphuric acid it forms magnesium sulphate. If a chloride ion is Cl^- and a sulphate ion is SO_4^{2-} , what is the formula of magnesium sulphate? Explain your answer.

..... [2]

- (iii) What salt is formed when magnesium reacts with nitric acid?

..... [1]

High Demand Questions

QUESTIONSHEET 3

Below is a section of the reactivity series for metals.

potassium
calcium
magnesium
zinc
lead
copper

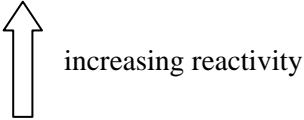

Use this reactivity series to answer the following questions.

- (a) Predict if there will be a reaction when the following chemicals are added together.
If you predict a react, write a word equation for it.

- (i) zinc and copper sulphate solution [2]

prediction

.....

equation

.....

- (ii) Calcium and potassium sulphate solution [1]

prediction

.....

equation

.....

- (iii) Magnesium and zinc sulphate solution [2]

prediction

.....

equation

.....

- (b) In a displacement reaction, two metals of different reactivity 'compete' for oxygen.
In such a reaction, oxidation and reduction occur simultaneously.

- (i) What is meant by reduction?
-
- [1]

(Continued...)

QUESTIONSHEET 3 CONTINUED

(ii) Write a word equation for the reaction between magnesium and copper(II) oxide.

..... [1]

(iii) In the equation, circle the reducing agent.

[1]

(iv) The reaction between magnesium and copper(II) oxide needs to be heated. The heat supplies the activation energy. What is meant by the term 'activation energy'?

.....
..... [2]

(c) In a series of experiments it was found that carbon would react with zinc oxide, but not with magnesium oxide.

(i) Write down the name of another metal oxide, which would react with carbon.

..... [1]

(ii) Write the name of another metal oxide, which would not react with carbon.

..... [1]

www.chemactive.com

A student investigated the different reactivities of a set of metals by placing pieces of each metal in metal nitrate solutions.

The table below shows some of the results.

solution	aluminium	barium	lithium	magnesium
aluminium nitrate		✓		✓
barium nitrate			✓	✗
lithium nitrate	✗			
magnesium nitrate	✗	✓	✓	

✓ = reaction observed

✗ = no reaction

- (a) Use the results given to put the metals in order of reactivity starting with the most reactive.

_____ [2]

- (b) Use the reactivity series in (a) to complete the table. [3]

- (c) It is known that aluminium is more reactive than silver.
However, when a piece of aluminium is put in a solution of silver nitrate, no reaction is observed.
Explain this result.

.....

 [3]

High Demand Questions

QUESTIONSHEET 5

Below is a section of the reactivity series of metals.
The non-metal, carbon is also included.

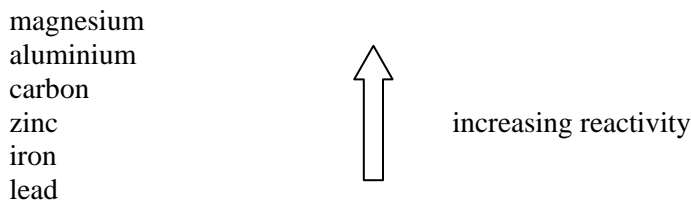

Both aluminium and iron are found in nature as their oxides.
The methods of extracting the pure metals depend on their reactivity.

(a) Aluminium is extracted by electrolysis from its oxide.

(i) What is the name of an aluminium ore consisting of aluminium oxide?

..... [1]

(ii) During electrolysis, cryolite is added to molten aluminium oxide.
Explain why.

.....
..... [2]

(iii) Write balanced ionic equations for the reactions occurring at the electrodes during the electrolysis.

anode

..... [1]

cathode

..... [1]

(b) Iron is extracted from its oxide by reduction in a blast furnace.

(i) What is the name of the iron ore consisting of iron(III) oxide?

..... [1]

(ii) Explain what is meant by 'reduction'.

..... [1]

(Continued...)

QUESTIONSHEET 5 CONTINUED

- (iii) The main reducing agent in the blast furnace is carbon monoxide, which reacts with iron(III) oxide to produce pure iron.
Balance the equation for this reaction.



- (iv) A waste product of the blast furnace is called slag.
Give one use for slag.

..... [1]

- (c) Explain why aluminium is extracted by electrolysis, rather than in a blast furnace.

.....
..... [2]

www.chemactive.com

A new metal has been discovered.

It has the name mancium with the symbol M.

Mancium reacts violently with water to form a colourless gas and an alkaline solution. The alkaline solution is mancium hydroxide with formula MOH.

Mancium also forms a chloride salt with formula MCl.

- (a) Describe a test to show that the solution formed with water was alkaline.

TEST

..... [1]

RESULT

..... [1]

- (b) Use the information to predict the formula of mancium oxide.

..... [1]

- (c) In which group of the Periodic Table would you place mancium.

Give a reason for your answer.

GROUP

..... [1]

REASON

..... [1]

- (d) Part of the reactivity series for metals is shown below.

CALCIUM
ZINC
IRON
COPPER

Rewrite this reactivity series and include the metal mancium.

Give a reason for your position.

REACTIVITY SERIES

REASON

.....
..... [2]

(Continued...)

QUESTIONSHEET 6 CONTINUED

- (e) Mancunium was found to react with copper sulphate solution.
Give the names of the products of the reaction.

..... [1]

- (f) Mancunium hydroxide reacts with sulphuric acid to form a salt and water.

- (i) Complete the word equation by naming the salt formed in this reaction.

mancunium hydroxide + sulphuric acid \rightarrow _____ + water [1]

- (ii) Complete the symbol equation for this reaction.

_____ MOH + H₂SO₄ \rightarrow _____ [2]

www.chemactive.com

Reactions that give out a large amount of heat have many uses.

A company has invented 'cook-in-the-can' meals.

A ring is pulled which ignites the chemicals surrounding the can. The chemicals react and produce heat, which cooks the food in the can.

One of the reactions used is a mixture of aluminium powder and iron(III) oxide.

The aluminium used is finely powdered.

(a)(i) Complete the word equation below for this reaction:

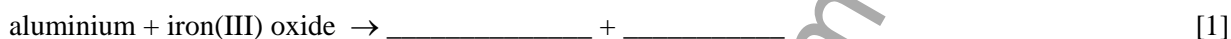

(ii) Balance the symbol equation for this reaction.



(b) Use your ideas of the reactivity series of metals to explain why these substances react.

.....

 [2]

(c) Suggest a reason why the aluminium used is powdered.

.....

 [2]

(d)(i) John tried out some reactions in the laboratory that may produce heat.

He used a mixture of powdered copper metal and iron(III) oxide.

Give a reason why John was unsuccessful.

.....
 [2]

(ii) John found a copy of the reactivity series in a chemistry textbook.

It is shown below:

- magnesium
- zinc
- iron
- silver
- gold

Use this information to name another metal that John could use that would react with iron(III) oxide.

..... [1]

Some students were investigating the reaction between zinc metal and copper sulphate solution. They set up the apparatus as shown in the diagram below.

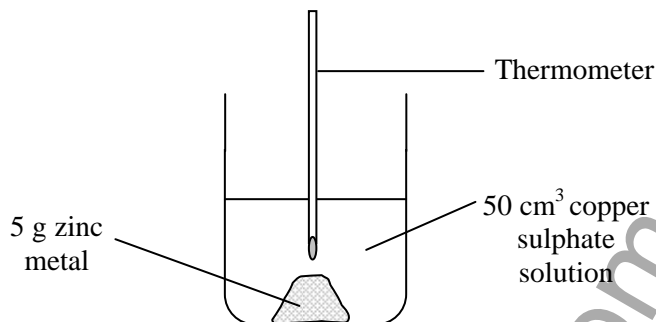

(a) Name a piece of apparatus that could be used to measure out 50 cm³ of copper sulphate solution.
 [1]

(b) Name a piece of apparatus that could be used to measure 5 g of zinc metal.
 [1]

(c) The reaction is exothermic. Describe what the students would see.

 [3]

(d) Complete the equation for the reaction

$$\text{Zn} + \text{CuSO}_4 \rightarrow \text{_____} + \text{_____}$$
 [1]

(e) Zinc metal was present 'in excess' in this experiment. Explain what is meant by 'in excess'.
 [1]

(f) The students repeated the experiment but added zinc to magnesium sulphate solution.
 (i) What would the students see?
 [1]

(ii) Explain your answer.

 [2]

GCSE CHEMISTRY METALS & THE REACTIVITY SERIES

Medium Demand Questions

QUESTIONSHEET 9

Reactions were carried out using four different metals - A, B, C and D.

The table below shows the results of reacting these metals with air and then with water.

metal	reaction with air	reaction with water
A	changes colour on heating	no reaction
B	burns in air to form a white solid	bubbles of gas on surface
C	no reaction	no reaction
D	changes colour when placed in air	fizzes vigorously

- (a) From the reactions in the table, give one example of a chemical change. [1]

Give a reason for your choice.

METAL

.....

REACTION WITH

.....

REASON

.....

- (b) Use the information in the table to place the four metals in order of reactivity. [2]

MOST REACTIVE _____

LEAST REACTIVE _____

- (c) Which of the four metals is most likely to be an alkali metal?
Give a reason for your choice.

The group I metal is likely to be _____

REASON

..... [2]

- (d) Which of the four metals would be found 'native'?

..... [1]

- (e) Metal A was found to be copper.
Write a word equation for the reaction of copper in air.

.....

..... [2]

- (f) A student wished to try the reaction between metal D and hydrochloric acid.
Explain why you should not carry out this reaction.

.....

..... [2]

TOTAL / 10

The following questions are all about the reactivity of the metals copper, iron, magnesium and potassium.

(a) Match up each of the metals with its reaction with water. (The first one has been done for you)

copper	reacts with steam
iron	vigorous reaction in cold water
magnesium	no reaction with steam or water
potassium	reacts reversibly with steam

[3]

(b) When metals react with water, they form a metal hydroxide or a metal oxide, depending on their reactivity. From the metals above name a metal which forms:

(i) a metal hydroxide

..... [1]

(ii) a metal oxide

..... [1]

(c) When metals react with water they always release a gas.

(i) Name the gas released when metals react with water.

..... [1]

(ii) Describe a test to prove the identity of the gas

Test

..... [1]

Result

.....

..... [1]

In a series of experiments a small piece of metal was placed in a solution of a metal salt. Here is a list of reactions which take place.

- 1 aluminium + zinc sulphate solution
- 2 iron + lead nitrate solution
- 3 zinc + iron(II) sulphate solution

(a) Use the information above to place the metals in order of reactivity, starting with the most reactive.

_____ [2]

(b) In another reaction, magnesium was placed in copper(II) sulphate solution.

(i) Write a balanced equation for the reaction between magnesium and copper(II) sulphate.

..... [2]

(ii) What would you observe in this reaction?

..... [2]

(iii) Where in the series you have written would you place copper and magnesium?

copper

..... [1]

magnesium

..... [1]

(c) Use your reactivity series to predict whether there will be a reaction between these metals and solutions. Write word equations for any reactions you predict.

(i) iron and zinc sulphate

..... [1]

(ii) aluminium and iron(II) sulphate

..... [1]

A student placed a small piece of lithium in a trough. Below is a diagram of what the student observed.

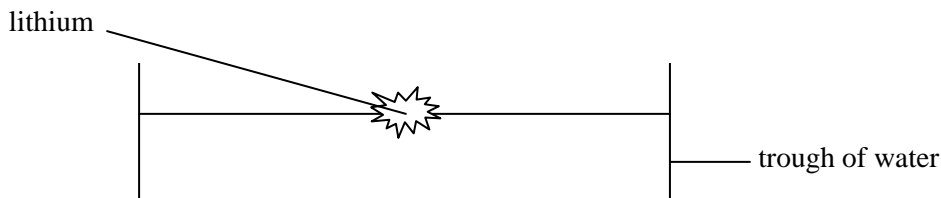

(a) The experiment was repeated with a piece of sodium.

(i) What other observations would be made?

.....

.....

..... [2]

(ii) Write a balanced symbol equation for the reaction of sodium with water.

..... [1]

(iii) If universal indicator is added to the trough, what colour would it turn?
What pH does this represent?

.....

..... [2]

(b) The experiment was repeated again, with a small piece of potassium.
What new observations would be made?

.....

.....

..... [2]

(c) The metals lithium, sodium and potassium are all in Group I of the periodic table.

(i) By what other name is Group I known?

..... [1]

QUESTIONSHEET 12 CONTINUED

(ii) Why do all metals in Group I react in a similar way?

.....
..... [1]

(iii) Describe and explain how the reactivity of Group I metals changes on descending the group.

.....
.....
.....
..... [4]

www.chemactive.com

Blackpool pier is made from an iron framework.

The iron legs stand in the sea.

Salt in sea water tends to speed up rusting.

The pier is protected from rusting by connecting blocks of scrap zinc metal to the iron legs of the pier.

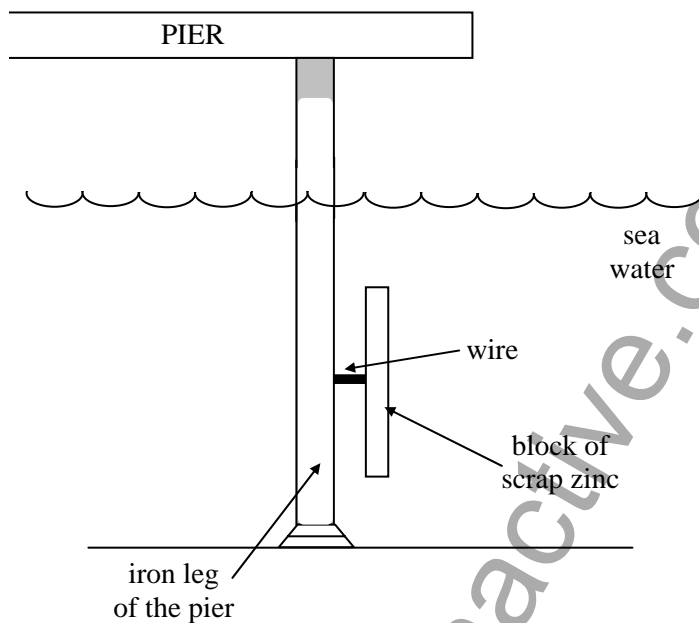

- (a) Name the two substances required for iron to rust.
 [1]
- (b) How does the zinc prevent the iron from rusting?
 [1]
- (c) Explain why zinc is suitable for this purpose.
 [1]
- (d) Why will the zinc only work when the tide is in and the blocks are covered in sea water?
 [1]
- (e) Mark on the diagram the direction in which the electrons flow in the wire. [1]

QUESTIONSHEET 13 CONTINUED

- (f) Predict what would happen if the zinc was replaced with copper metal.
Give a reason for your prediction.

PREDICTION

..... [1]

REASON

..... [1]

- (g) Salt water appears to make iron rust more quickly than water containing no salt.
Describe how you could carry out an experiment in test tubes with some iron nails to investigate this.

.....
.....
.....
.....
.....
.....
..... [3]

www.chemactive.com

The table shows the dates of discovery of some metals.

metal	date of discovery
potassium	1807
sodium	1807
magnesium	1755
zinc	1746
copper	known since ancient times

- (a) What is the pattern between the reactivity of a metal and its date of discovery?

.....
 [1]

- (b) A large piece of zinc metal was placed into blue copper sulphate solution.

- (i) Describe what you would see in this reaction.

.....

 [2]

- (ii) Complete the word equation for this reaction.

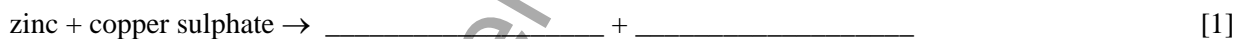

- (c) The temperature of the copper sulphate solution was recorded before the zinc was added and then several minutes later. The results were:

Temperature at start = 18°C
 Temperature after reaction = 31°C

- (i) Calculate the rise in temperature in this reaction.

..... [1]

- (ii) What word is used to describe reactions that give out energy?

..... [1]

- (iii) Give **two** ways in which the reaction could be changed to produce a higher temperature rise.

.....
 [2]

GCSE CHEMISTRY METALS & THE REACTIVITY SERIES

Medium Demand Questions

QUESTIONSHEET 15

A part of a reactivity series of metals is shown below:

- SODIUM
- MAGNESIUM
- ALUMINIUM
- CARBON
- ZINC
- IRON
- HYDROGEN
- COPPER

Use this information to explain as fully as you can the following reactions.

- (a) A brown solid is formed when a piece of magnesium metal is placed in copper sulphate solution.

.....
.....
..... [2]

- (b) Nothing happens when a piece of copper metal is placed in zinc sulphate solution.

.....
.....
..... [2]

- (c) Iron can be extracted from its oxide using carbon. Aluminium cannot be extracted from its oxide using carbon.

.....
.....
.....
.....
..... [3]

- (d) Zinc metal reacts with hydrochloric acid to form hydrogen gas.
Copper metal does not react with hydrochloric acid.

.....
.....
.....
..... [3]

- (e) Zinc carbonate decomposes on heating but sodium carbonate does not.

.....
..... [2]

TOTAL / 12

A group of students were investigating the effects of 'acid rain'. They decided to look at the effect of acid on metals used as building materials. Lead and copper are used for roofing and iron and aluminium can be used for window frames. Their chemistry book listed these metals in order of their reactivity as follows:

- ALUMINIUM
- IRON
- LEAD
- COPPER

The students tested the metals by adding dilute sulphuric acid to pieces of each of them. Only the iron seemed to give a reaction.

- (a) What would you see when iron reacted with the acid?
..... [1]
- (b) Explain why the aluminium did not react with the acid, even when the book said it was more reactive.
.....
.....
..... [2]
- (c) Suggest why sulphuric acid was used in this test and not any other acid.
.....
.....
..... [2]
- (d) The reaction with acid did not prove that lead was more reactive than copper.
The students had available:
- 1. small pieces of copper and lead
 - 2. solutions of copper nitrate and lead nitrate.
- (i) From these four substances choose two that the students should mix to show that lead is more reactive than copper.
- 1 _____ [1]
- 2 _____ [1]
- (ii) What would you see when the substances were mixed?
.....
..... [1]

QUESTIONSHEET 16 CONTINUED

(iii) Write a word equation for the reaction.

.....
..... [1]

(iv) Explain how this reaction proves that lead is more reactive than copper.

.....
..... [1]

www.chemactive.com

Low Demand Questions

QUESTIONSHEET 17

The reactivity series shows the relative reactivities of different metals.
Below is a reactivity series for eight metals.

sodium
calcium
magnesium
zinc
iron
lead
copper
mercury
silver

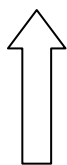

increasing reactivity

Use the series above to answer the following questions.

- (a) Name the metal which is found uncombined in the Earth's crust.
..... [1]
- (b) Which metal is stored under oil?
..... [1]
- (c) Which metal is a liquid at room temperature?
..... [1]
- (d) Which metal is shiny when cut, but tarnishes in a few seconds?
..... [1]
- (e) Which metal burns with a bright, white flame?
..... [1]
- (f) Which metal is extracted from its ore in a blast furnace?
..... [1]
- (g) Which metal is used to galvanise iron to prevent rusting?
..... [1]
- (h) Which metal reacts vigorously with cold water?
..... [1]
- (i) Which metal burns with a brick red flame?
..... [1]

Low Demand Questions

QUESTIONSHEET 18

The 'thermit' reaction is used to weld railway lines together.
The reaction mixture contains aluminium metal and iron oxide.
The substances are mixed in powder form in a clay pot.
The mixture is lit with a magnesium fuse.

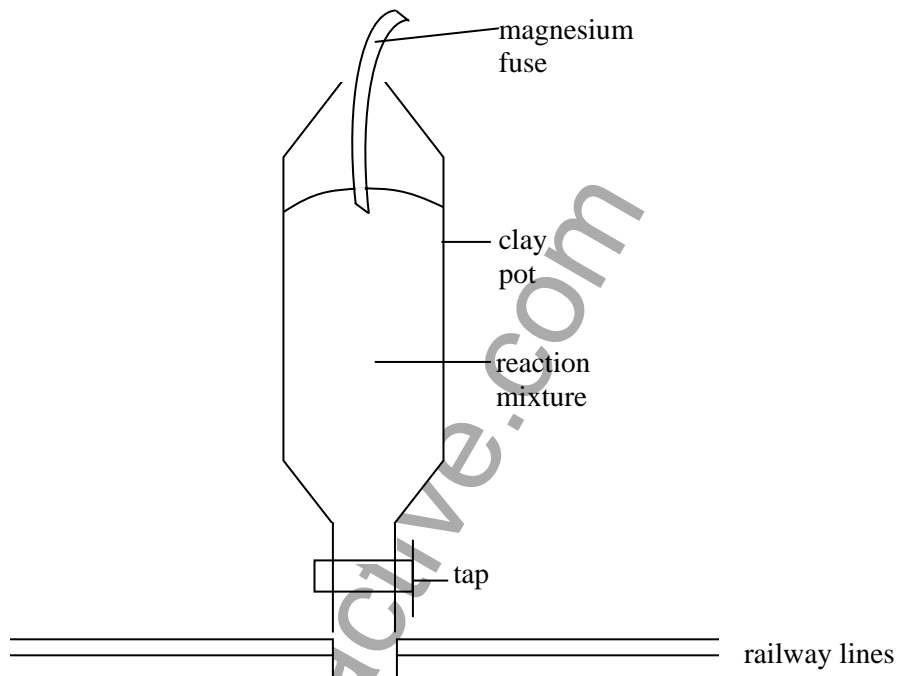

- (a) Complete the word equation for this reaction:

aluminium + iron oxide \rightarrow _____ + _____ [2]

- (b) The magnesium ribbon burns at 700°C yet the iron will only melt at 1500°C.
Explain why this reaction forms molten iron.

.....
..... [2]

- (c) Suggest a reason why the aluminium and iron oxide are in powder form.

.....
..... [2]

- (d) Suggest why a tap is needed at the bottom of the clay pot.

.....
..... [1]

(Continued...)

QUESTIONSHEET 18 CONTINUED

(e) Suggest a reason for using a clay pot to hold the mixture.

.....
..... [1]

(f) If copper powder is mixed with iron oxide there is no reaction.
Explain why this reaction works with aluminium metal but not copper metal.

.....
.....
.....
..... [3]

www.chemactive.com

In an experiment different metals were heated in a Bunsen burner flame for 30 seconds and then removed. The observations are given below.

metal	observation
copper	turned black - did not burn
magnesium	burned with white flame
silver	no obvious change

(a) Place the metals in order of reactivity, starting with the most reactive.
 _____ [1]

(b) When metals burn in air, an oxidation reaction takes place.
 (i) What is meant by 'oxidation'?

 [1]

(ii) Write a word equation for an oxidation reaction which happened in the experiment.
 [1]

(c) In another experiment, a piece of polished copper was placed in a solution of silver nitrate.
 (i) What was observed?
 [1]

(ii) Explain your answer.

 [2]

(d) In another experiment a piece of polished copper was placed in a solution of magnesium sulphate.
 (i) What was observed?
 [1]

(ii) Explain your answer.

 [2]

Low Demand Questions

QUESTIONSHEET 20

Magnesium reacts very slowly with water.

A piece of magnesium is kept under water for a week in the apparatus shown.

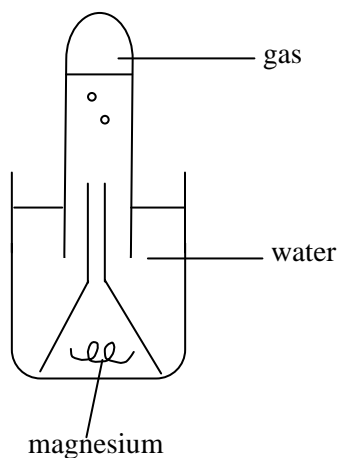

(a)(i) What gas is collected in the test tube?

..... [1]

(ii) A white solid forms on the surface of the magnesium.
What is this solid?

..... [1]

(b) magnesium will react much faster with steam.

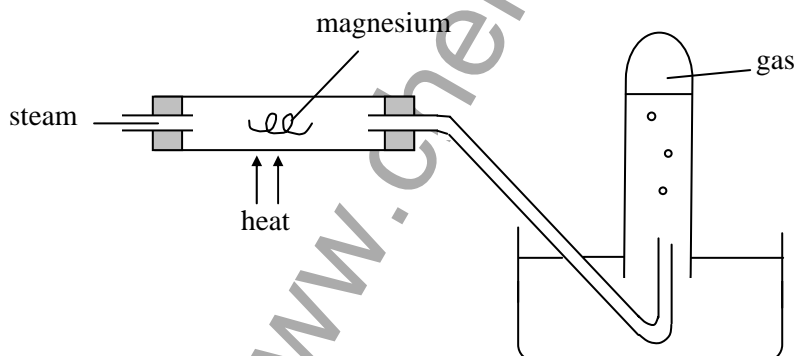

(i) Name the gas collected in the test tube.

..... [1]

(ii) Suggest **two** other metals which will react with steam in the same way as magnesium.

..... [2]

(iii) Name a metal that will not react in this way.

..... [1]

(Continued...)

QUESTIONSHEET 20 CONTINUED

(c) Explain why many items of jewellery are made from gold or silver and not from iron.

.....
.....
..... [3]

www.chemactive.com